

36V Low Power Dual/Quad Differential Comparators

Features

- **Wide Single-supply Voltage Range or Dual Supplies: +2 V to +36 V or ± 1.0 V to ± 18 V**
- **Very Low Supply Current (150 μ A/ch) Independent of Supply Voltage(0.75 mW/comparator at +5 V)**
- **Low Input Bias Current: 4 nA typ.**
- **Low Offset Voltage: ± 3.0 mV Max**
- **Offset Voltage Temperature Drift: 1 μ V/ $^{\circ}$ C**
- **Input Common-mode Voltage Range Includes Ground**
- **Internal Differential Input Voltage Range Equal to The Supply Voltage**
- **TTL, DTL, ECL, MOS, CMOS compatible Outputs**
- **Open drain output**
- **ESD Clamps on the Inputs Increase the Ruggedness of the Device Without Affecting Performance**
- **Low Output Saturation**
- **-40° C to 125° C Operation Range**
- **ESD Rating:
Robust 2KV – HBM, 2KV – CDM**
- **High Performance Drop-In Compatible With 339, 339, 2903, 2901 Series Product**

Description

The devices in this series consist of dual/quad independent single or dual supply voltage comparators on a single monolithic substrate. The common mode input voltage range includes ground even when operated from a single supply, and the low power supply current drain makes these comparators suitable for battery operation. These types were designed to directly interface with TTL and CMOS, Current drain is independent of the supply voltage. The outputs can be connected to other open-collector outputs to achieve wired-AND relationships.

The LM2903 is dual channel version available in 8-pin SOP package. The LM2901 is quad channel version available in 14-pin SOP package. All devices are specified for the temperature range of -40° C to $+125^{\circ}$ C.

✚ 3PEAK and the 3PEAK logo are registered trademarks of 3PEAK INCORPORATED. All other trademarks are the property of their respective owners.

Applications

- High-speed Line or Digital Line Receivers
- High Speed Sampling Circuits
- Peak and Zero-crossing Detectors
- Threshold Detectors/Discriminators
- Sensing at Ground or Supply Line

Pin Configuration (Top View)

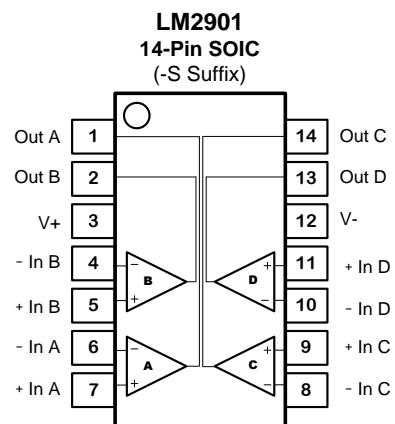
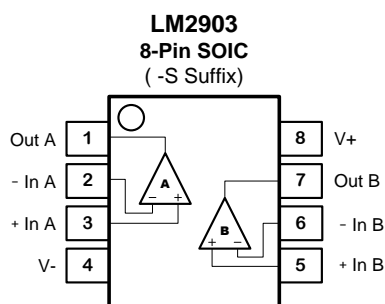

LM2903/LM2901

36V Low Power Dual/Quad Differential Comparators

Order Information

Model Name	Order Number	Package	Transport Media, Quantity	Marking Information
LM2903	LM2903-SR	8-Pin SOP	Tape and Reel, 4,000	LM2903
LM2901	LM2901-SR	14-Pin SOP	Tape and Reel, 2,500	LM2901

Absolute Maximum Ratings Note 1

Supply Voltage: $V^+ - V^-$	42V	Operating Temperature Range.....	-40°C to 125°C
Input Voltage.....	$V^- - 0.3$ to $V^+ + 0.3$	Maximum Junction Temperature.....	150°C
Input Current: +IN, -IN, <small>Note 2</small>	± 20 mA	Storage Temperature Range.....	-65°C to 150°C
Output Current: OUT.....	± 20 mA	Lead Temperature (Soldering, 10 sec)	260°C
Output Short-Circuit Duration <small>Note 3</small>	Infinite		

Note 1: Stresses beyond those listed under Absolute Maximum Ratings may cause permanent damage to the device. Exposure to any Absolute Maximum Rating condition for extended periods may affect device reliability and lifetime.

Note 2: The inputs are protected by ESD protection diodes to each power supply. If the input extends more than 500mV beyond the power supply, the input current should be limited to less than 10mA.

Note 3: A heat sink may be required to keep the junction temperature below the absolute maximum. This depends on the power supply voltage and how many amplifiers are shorted. Thermal resistance varies with the amount of PC board metal connected to the package. The specified values are for short traces connected to the leads.

ESD, Electrostatic Discharge Protection

Symbol	Parameter	Condition	Minimum Level	Unit
HBM	Human Body Model ESD	MIL-STD-883H Method 3015.8	2	kV
CDM	Charged Device Model ESD	JEDEC-EIA/JESD22-C101E	2	kV

36V Low Power Dual/Quad Differential Comparators

Electrical Characteristics

The ● denotes the specifications which apply over the full operating temperature range(-40°C ~ +125°C), otherwise specifications are at T_A = 27°C. V_{DD} = +5V, V_{IN+} = V_{DD}, V_{IN-} = 1.2V, R_{PU}=10kΩ, C_L=15pF.

SYMBOL	PARAMETER	CONDITIONS		MIN	TYP	MAX	UNITS
V _{DD}	Supply Voltage		●	2		36	V
V _{OS}	Input Offset Voltage ^{Note 1}	V _{CC} = 5 V to MAX, V _{IC} = V _{ICR(min)} , V _O = 1.4V		-3	±0.6	+3	mV
V _{OS} TC	Input Offset Voltage Drift ^{Note 1}	V _{CM} = 1.2V	●		1	2	μV/°C
I _B	Input Bias Current	V _{DM} = 0.5V			4		nA
C _{IN}	Input Capacitance	Differential Common Mode			2.5 5		pF
V _{CM}	Common-mode Input Voltage Range	25°C		0		V _{DD} -1.5	V
		-40°C ~ +125°C	●	0		V _{DD} -2	V
A _{VD}	Large-signal Differential-voltage Amplification	V _{CC} = 15 V, V _O = 1.4 V to 11.4 V, R _L ≥ 15 kΩ to V _{CC}		100	400		V/mV
I _{OH}	High-level Output Current	V _{OH} = 5 V, V _{ID} = 1 V			25	70	nA
		V _{OH} = 30 V, V _{ID} = 1 V	●			7	μA
V _{OL}	Low-Level Output Voltage	I _{OL} = 4mA, V _{ID} = -1V			250	400	mV
			●				700
I _{OL}	Low-level Output Current	V _{OL} = 1.5 V, V _{ID} = -1 V		10			mA
I _Q	Quiescent Current per Comparator	V _{CC} = 5 V			150	300	μA
		V _{CC} = 30 V			150	300	μA
t _{RT}	Response time	R _L connected to 5 V through 5.1 kΩ, C _L = 15 pF, See Note 3				2	μs
						0.5	

Note 1: The input offset voltage is the average of the input-referred trip points.

36V Low Power Dual/Quad Differential Comparators

Typical Performance Characteristics

$V_S = +5V$, $V_{CM} = 0V$, $R_L = \text{Open}$, unless otherwise specified.

Supply Current vs. Supply Voltage

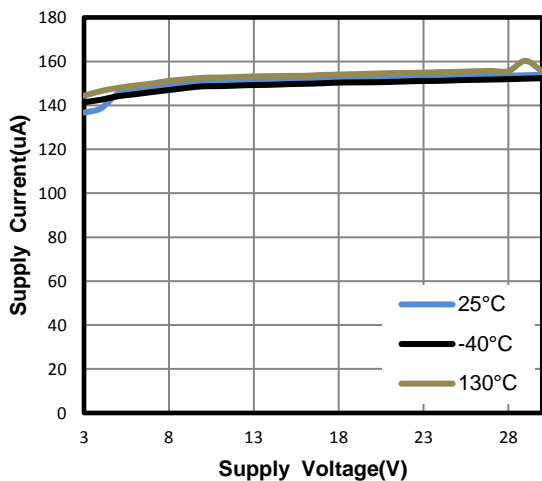

Response Time for Various Input Overdrives - Positive Transition

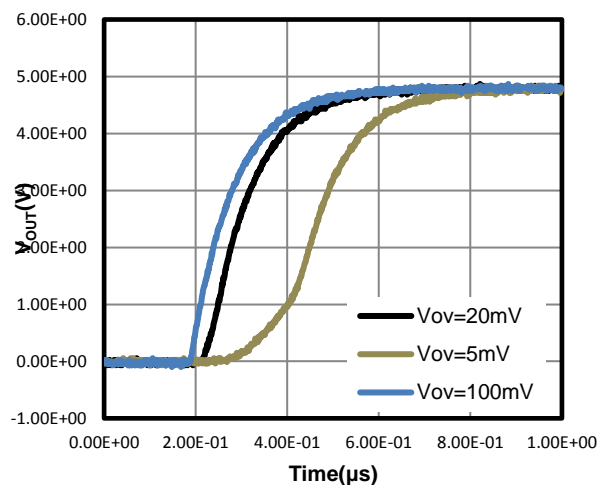

Response Time For Various Input Overdrives - Negative Transition

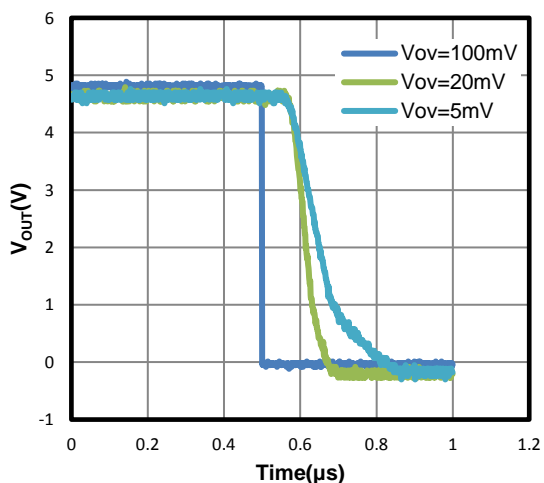

Negative Output Swing vs. Sink Current

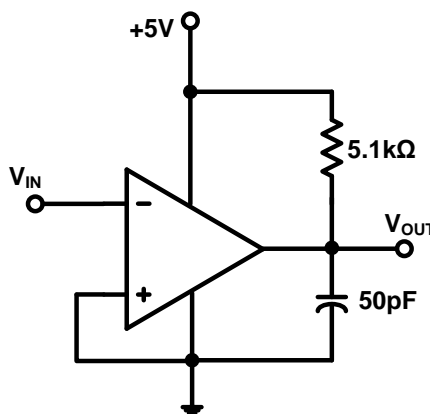
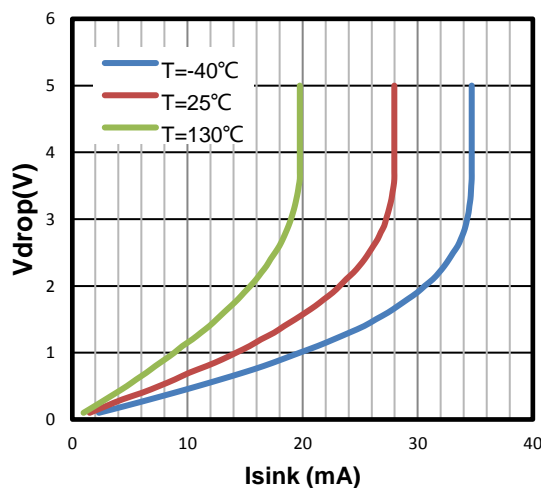

Response Time Test Circuit

36V Low Power Dual/Quad Differential Comparators

Pin Functions

-IN: Inverting Input of the Comparator. Voltage range of this pin can go from V^- to $V^+ - 1.5V$.

+IN: Non-Inverting Input of Comparator. This pin has the same voltage range as $-IN$.

V^+ (V_{DD}): Positive Power Supply. Typically the voltage is from 2V to 36V. Split supplies are possible as long as the voltage between V^+ and V^- is between 2V and 36V. A bypass capacitor of $0.1\mu F$ as close to the part as possible should be used between

power supply pins or between supply pins and ground.

V^- (V_{SS}): Negative Power Supply. It is normally tied to ground. It can also be tied to a voltage other than ground as long as the voltage between V^+ and V^- is from 2V to 36V. If it is not connected to ground, bypass it with a capacitor of $0.1\mu F$ as close to the part as possible.

OUT: Comparator Output. The voltage range extends to within millivolts of each supply rail.

Operation

The LM2903/LM2901 family single-supply comparators feature internal hysteresis, high speed, and low power. Input signal range extends beyond the negative and positive power supplies. The output can even extend all the way to the negative supply.

The input stage is active over different ranges of common mode input voltage. Rail-to-rail input voltage range and low-voltage single-supply operation make these devices ideal for portable equipment.

Applications Information

Inputs

The LM2903/2901 comparator family uses CMOS transistors at the input which prevent phase inversion when the input pins exceed the supply voltages. Figure 1 shows an input voltage exceeding both supplies with no resulting phase inversion.

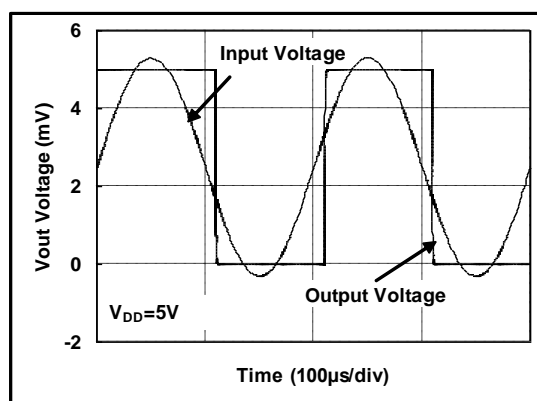

Figure 1. Comparator Response to Input Voltage

The electrostatic discharge (ESD) protection input structure of two back-to-back diodes and $1k\Omega$ series resistors are used to limit the differential input voltage applied to the precision input of the comparator by clamping input

36V Low Power Dual/Quad Differential Comparators

voltages that exceed supply voltages, as shown in Figure 2. Large differential voltages exceeding the supply voltage should be avoided to prevent damage to the input stage.

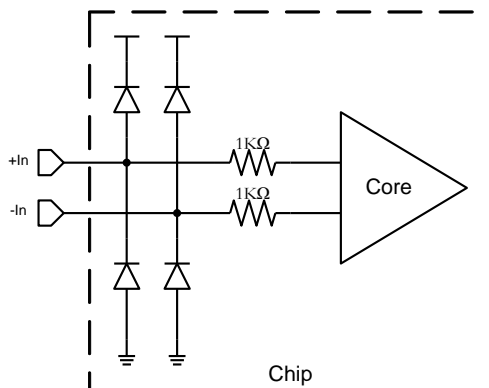

Figure 2. Equivalent Input Structure

External Hysteresis

Greater flexibility in selecting hysteresis is achieved by using external resistors. Hysteresis reduces output chattering when one input is slowly moving past the other. It also helps in systems where it is best not to cycle between high and low states too frequently (e.g., air conditioner thermostatic control). Output chatter also increases the dynamic supply current.

Non-Inverting Comparator with Hysteresis

A non-inverting comparator with hysteresis requires a two-resistor network, as shown in Figure 3 and a voltage reference (V_r) at the inverting input.

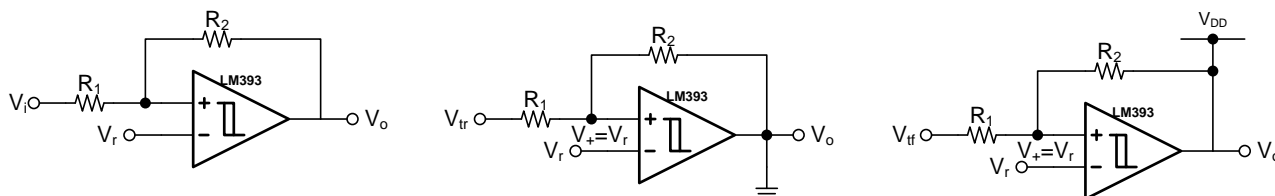

Figure 3. Non-Inverting Configuration with Hysteresis

When V_i is low, the output is also low. For the output to switch from low to high, V_i must rise up to V_{tr} . When V_i is high, the output is also high. In order for the comparator to switch back to a low state, V_i must equal V_{tr} before the non-inverting input V_+ is again equal to V_r .

$$V_r = \frac{R_2}{R_1 + R_2} V_{tr}$$

$$V_r = (V_{DD} - V_{tr}) \frac{R_1}{R_1 + R_2} + V_{tr}$$

$$V_{tr} = \frac{R_1 + R_2}{R_2} V_r$$

36V Low Power Dual/Quad Differential Comparators

$$V_{tr} = \frac{R_1 + R_2}{R_2} V_r - \frac{R_1}{R_2} V_{DD}$$

$$V_{hyst} = V_{tr} - V_{tf} = \frac{R_1}{R_2} V_{DD}$$

Inverting Comparator with Hysteresis

The inverting comparator with hysteresis requires a three-resistor network that is referenced to the comparator supply voltage (V_{DD}), as shown in Figure 4.

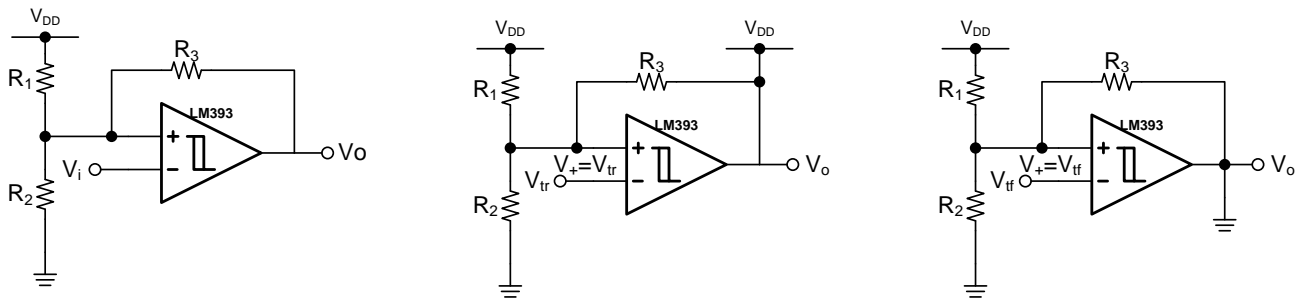

Figure 4. Inverting Configuration with Hysteresis

When V_i is greater than V_+ , the output voltage is low. In this case, the three network resistors can be presented as paralleled resistor $R_2 \parallel R_3$ in series with R_1 . When V_i at the inverting input is less than V_+ , the output voltage is high. The three network resistors can be represented as $R_1 \parallel R_3$ in series with R_2 .

$$V_{tr} = \frac{R_2}{R_1 \parallel R_3 + R_2} V_{DD}$$

$$V_{tf} = \frac{R_2 \parallel R_3}{R_2 \parallel R_3 + R_1} V_{DD}$$

$$V_{hyst} = V_{tr} - V_{tf} = \frac{R_1 \parallel R_2}{R_1 \parallel R_2 + R_3} V_{DD}$$

Low Input Bias Current

The LM2903/2901 family is a CMOS comparator family and features very low input bias current in pA range. The low input bias current allows the comparators to be used in applications with high resistance sources. Care must be taken to minimize PCB Surface Leakage. See below section on “PCB Surface Leakage” for more details.

PCB Surface Leakage

In applications where low input bias current is critical, Printed Circuit Board (PCB) surface leakage effects need to be considered. Surface leakage is caused by humidity, dust or other contamination on the board. Under low humidity conditions, a typical resistance between nearby traces is $10^{12}\Omega$. A 5V difference would cause 5pA of

36V Low Power Dual/Quad Differential Comparators

current to flow, which is greater than the LM2903/LM2901's input bias current at +27°C ($\pm 6\mu\text{A}$, typical). It is recommended to use multi-layer PCB layout and route the comparator's -IN and +IN signal under the PCB surface.

The effective way to reduce surface leakage is to use a guard ring around sensitive pins (or traces). The guard ring is biased at the same voltage as the sensitive pin. An example of this type of layout is shown in Figure 5 for Inverting configuration application.

1. For Non-Inverting Configuration:

- a) Connect the non-inverting pin ($V_{\text{IN}+}$) to the input with a wire that does not touch the PCB surface.
- b) Connect the guard ring to the inverting input pin ($V_{\text{IN}-}$). This biases the guard ring to the same reference as the comparator.

2. For Inverting Configuration:

- a) Connect the guard ring to the non-inverting input pin ($V_{\text{IN}+}$). This biases the guard ring to the same reference voltage as the comparator (e.g., $V_{\text{DD}}/2$ or ground).
- b) Connect the inverting pin ($V_{\text{IN}-}$) to the input with a wire that does not touch the PCB surface.

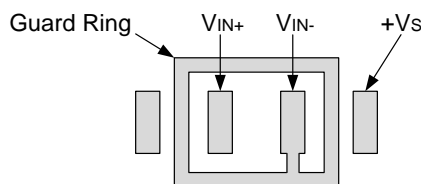

Figure 5. Example Guard Ring Layout for Inverting Comparator

Ground Sensing and Rail to Rail Output

The LM2903/2901 family implements a rail-to-rail topology that is capable of swinging to within 10mV of either rail. Since the inputs can go 300mV beyond either rail, the comparator can easily perform 'true ground' sensing.

The maximum output current is a function of total supply voltage. As the supply voltage of the comparator increases, the output current capability also increases. Attention must be paid to keep the junction temperature of the IC below 150°C when the output is in continuous short-circuit condition. The output of the amplifier has reverse-biased ESD diodes connected to each supply. The output should not be forced more than 0.5V beyond either supply, otherwise current will flow through these diodes.

ESD

The LM2903/2901 family has reverse-biased ESD protection diodes on all inputs and output. Input and output pins cannot be biased more than 300mV beyond either supply rail.

Power Supply Layout and Bypass

The LM2903/2901 family's power supply pin should have a local bypass capacitor (i.e., 0.01 μF to 0.1 μF) within 2mm for good high frequency performance. It can also use a bulk capacitor (i.e., 1 μF or larger) within 100mm to provide large, slow currents. This bulk capacitor can be shared with other analog parts.

Good ground layout improves performance by decreasing the amount of stray capacitance and noise at the comparator's inputs and outputs. To decrease stray capacitance, minimize PCB lengths and resistor leads, and place external components as close to the comparator's pins as possible.

Proper Board Layout

The LM2903/2901 family is a series of fast-switching, high-speed comparator and requires high-speed layout considerations. For best results, the following layout guidelines should be followed:

1. Use a printed circuit board (PCB) with a good, unbroken low-inductance ground plane.
2. Place a decoupling capacitor (0.1 μF ceramic, surface-mount capacitor) as close as possible to supply.
3. On the inputs and the output, keep lead lengths as short as possible to avoid unwanted parasitic feedback around the comparator. Keep inputs away from the output.

36V Low Power Dual/Quad Differential Comparators

4. Solder the device directly to the PCB rather than using a socket.
5. For slow-moving input signals, take care to prevent parasitic feedback. A small capacitor (1000 pF or less) placed between the inputs can help eliminate oscillations in the transition region. This capacitor causes some degradation to propagation delay when the impedance is low. The topside ground plane should be placed between the output and inputs.
6. The ground pin ground trace should run under the device up to the bypass capacitor, thus shielding the inputs from the outputs.

Typical Applications

IR Receiver

The LM2903/2901 is an ideal candidate to be used as an infrared receiver shown in Figure 6. The infrared photo diode creates a current relative to the amount of infrared light present. The current creates a voltage across R_D . When this voltage level cross the voltage applied by the voltage divider to the inverting input, the output transitions. Optional R_o provides additional hysteresis for noise immunity.

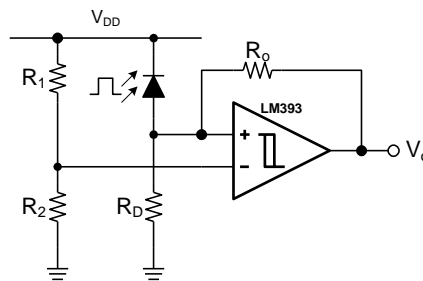

Figure 6. IR Receiver

Relaxation Oscillator

A relaxation oscillator using LM2903/2901 is shown in Figure 7. Resistors R_1 and R_2 set the bias point at the comparator's inverting input. The period of oscillator is set by the time constant of R_4 and C_1 . The maximum frequency is limited by the large signal propagation delay of the comparator. LM2903/2901's low propagation delay guarantees the high frequency oscillation.

If the inverted input (V_{C1}) is lower than the non-inverting input (V_A), the output is high which charges C_1 through R_4 until V_{C1} is equal to V_A . The value of V_A at this point is

$$V_{A1} = \frac{V_{DD} \cdot R_2}{R_1 \parallel R_3 + R_2}$$

At this point the comparator switches pulling down the output to the negative rail. The value of V_A at this point is

$$V_{A2} = \frac{V_{DD} \cdot R_2 \parallel R_3}{R_1 + R_2 \parallel R_3}$$

If $R_1=R_2=R_3$, then $V_{A1}=2V_{DD} / 3$, and $V_{A2}= V_{DD}/3$

The capacitor C_1 now discharges through R_4 , and the voltage V_C decreases till it is equal to V_{A2} , at which point the comparator switches again, bringing it back to the initial stage. The time period is equal to twice the time it takes to discharge C_1 from $2V_{DD}/3$ to $V_{DD}/3$. Hence the frequency is:

$$f_{\text{req}} = \frac{1}{2 \cdot \ln 2 \cdot R_4 \cdot C_1}$$

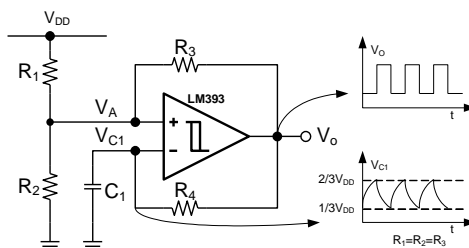

Figure 7. Relaxation Oscillator

Windowed Comparator

Figure 8 shows one approach to designing a windowed comparator using a single LM2903/2901 chip. Choose different thresholds by changing the values of R1, R2, and R3. OutA provides an active-low undervoltage indication, and OutB gives an active-low overvoltage indication. ANDing the two outputs provides an active-high, power-good signal. When input voltage V_i reaches the overvoltage threshold V_{OH} , the OutB gets low. Once V_i falls to the undervoltage threshold V_{UH} , the OutA gets low. When $V_{UH} < V_i < V_{OH}$, the AND Gate gets high.

$$V_{OH} = V_r \cdot (R_1 + R_2 + R_3) / R_1$$

$$V_{UH} = V_r \cdot (R_1 + R_2 + R_3) / (R_1 + R_2)$$

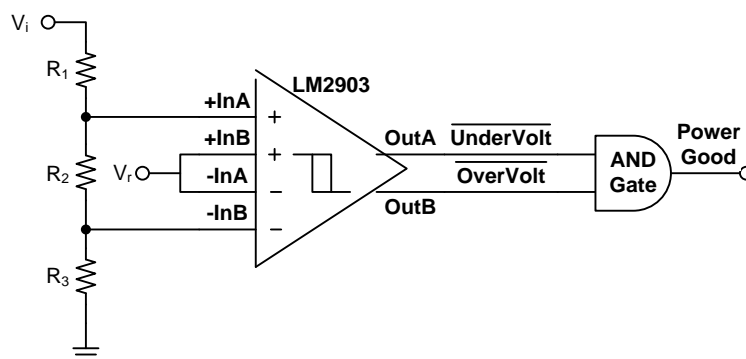
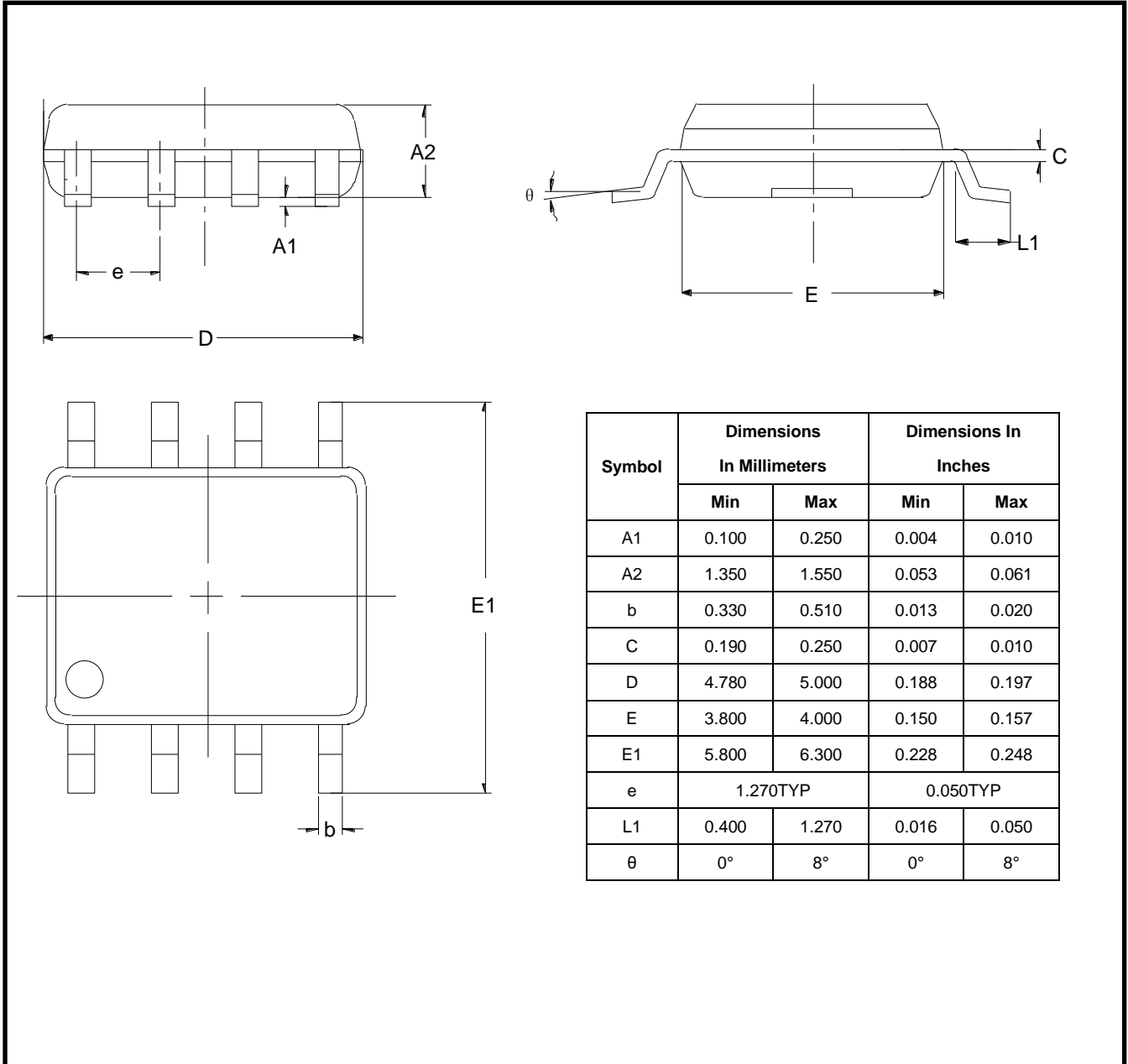

Figure 8. Windowed Comparator

36V Low Power Dual/Quad Differential Comparators

Package Outline Dimensions

SO-8 (SOIC-8)



LM2903/LM2901

36V Low Power Dual/Quad Differential Comparators

Package Outline Dimensions

SO-14 (SOIC-14)

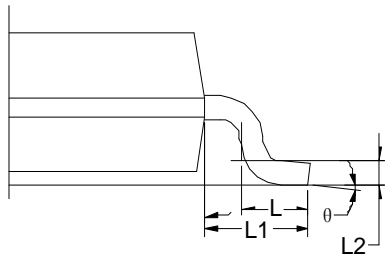
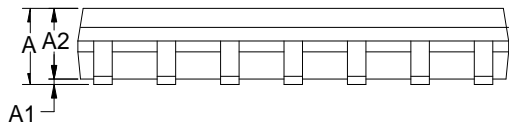
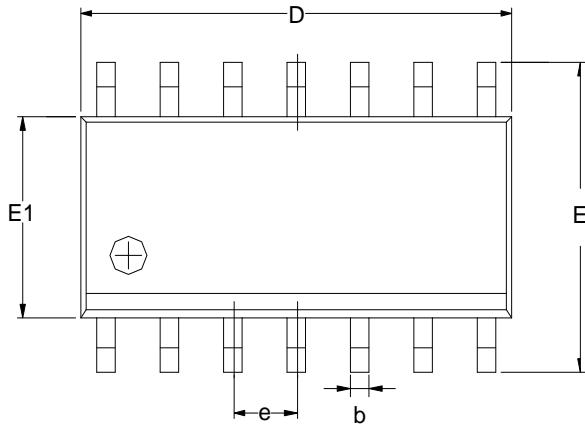

Symbol	Dimensions In Millimeters		
	MIN	TYP	MAX
A	1.35	1.60	1.75
A1	0.10	0.15	0.25
A2	1.25	1.45	1.65
b	0.36		0.49
D	8.53	8.63	8.73
E	5.80	6.00	6.20
E1	3.80	3.90	4.00
e	1.27 BSC		
L	0.45	0.60	0.80
L1	1.04 REF		
L2	0.25 BSC		
θ	0°		8°